



**INDIAN INSTITUTE OF SCIENCE EDUCATION AND
RESEARCH THIRUVANANTHAPURAM (IISERTVM)
(Govt. of India, Ministry of H.R.D)**

PH: 0471-2597454
FAX: 0471-2597427
EMAIL: PURCHASESTORES@IISERTVM.AC.IN

CET CAMPUS, KULATHUR, ENGINEERING COLLEGE.P.O
THIRUVANANTHAPURAM 695016,
KERALA, INDIA.

Date: 11/07/2017

INVITATION TO TENDER

No: IISER/PUR/507/SHT/XRD

Due Date: 17th July/2017 [12:00PM]

Date of Opening: 17th July/2017 [12.30 PM]

Dear Sirs,

SUB: Moving Equipment from Transit Campus to Permanent Campus.

Sealed Quotations are invited for moving various equipment's and materials & furniture's, Lab equipment's and other research oriented equipment's. (Used & Unused) as stated in the enclosed list. Bidders are required to submit at least one copy of the work order or work completion report (self-attested) to prove the expertise in similar shifting activities in Govt. Organizations. Bids submitted without the said documentary evidence will not be considered for evaluation. Interested vendors may contact Purchase & Stores Office (0471-2597454) for facilitation of site visit

Details as per annexure I

Please quote your lowest rate as per the following terms. Your offer in sealed cover **SUPERSCRIBING TENDER NUMBER AND DUE DATE** shall reach us on or before the due date and time.

- Payment** : Against successful completion of Work.
- Schedule** : The Eligible Vendors is required to Start the Work Immediately on Getting the Order from Our End
- Completion Time** : Within 5-6 Days
- Other Charges** : Should quote inclusive of all charges.

Thanking You,

Yours Faithfully

Deputy Registrar
In-Charge

[Purchase & Stores]

P.S. CATALOGUE/LEAFLET FEATURING ALL TECHNICAL SPECS/INFORMATION SHALL ACCOMPANY THE OFFER.

Annexure I to Enquiry No. IISER/PUR/507/SHT/XRD dt.11/07/2017

Following Packing Material is required to carry out the shifting. {the Diagram of Package is enclosed]

Box Dimensions:

1. 158 x 145 x 150 cm
2. 168 x 132 x 135 cm
3. 119 x 107 x 135 cm
4. 102 x 94 x 74 cm

Total weight (all four boxes together) ~ 1200 Kgs.

Box Specifications:

Making of different sizes of wooden boxes as above for packing equipment using mango tree wood or equivalent, including cost of all fix arrangements etc. Main wooden runners are of minimum size 3.5 inch x 1.5 inch placed at 100mm spacing above of size 4 inch x 3 inch runners at 350mm spacing in the bottom. Wooden runners should be free from all surface contaminants, smooth and dust free, etc. On the runners, providing and fixing of 18mm approved plywood for covering four sides of boxes including the top with necessary fixing arrangements and screws etc; all complete as per the direction of the officer in charge. Detailed drawing of a typical box is attached.

Packing material:

1. Air bubble wrap, 1 meter wide, 100 meters length
2. Packing tape (Brown, 3 inch) - 5 rolls
3. Thermocol sheets - 20 nos.

Packing material quantities are approximate. Vendors to visit the site and quote as required.

A handwritten signature in blue ink, followed by the date '11/07/17' written below it.

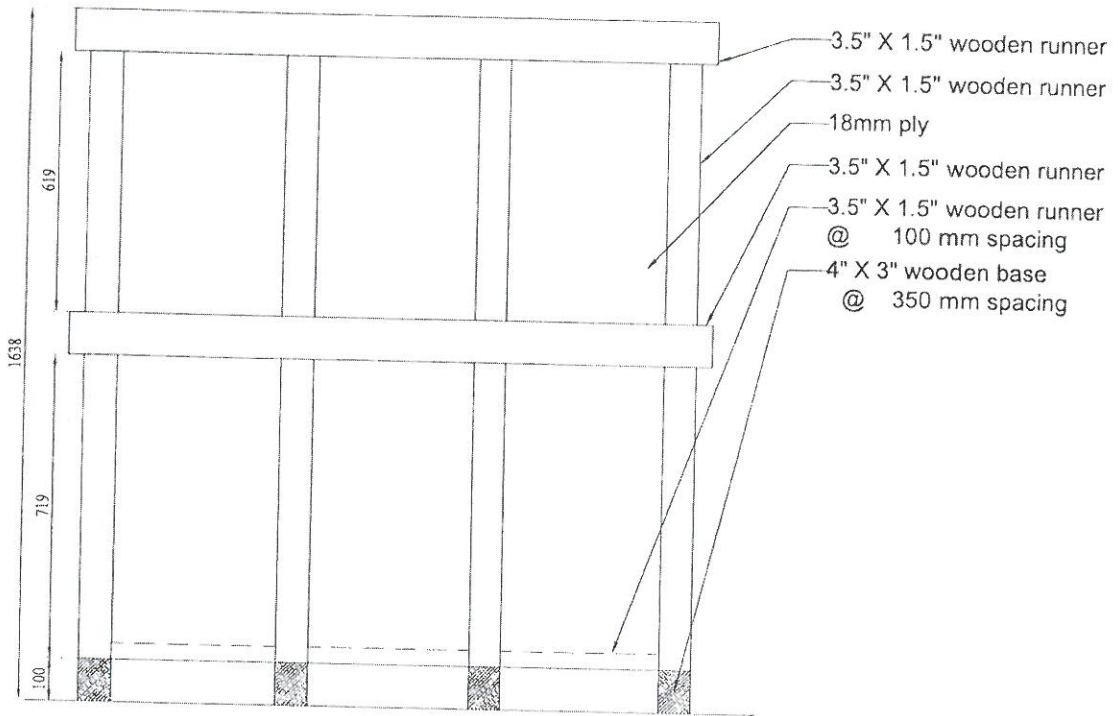

ELEVATION

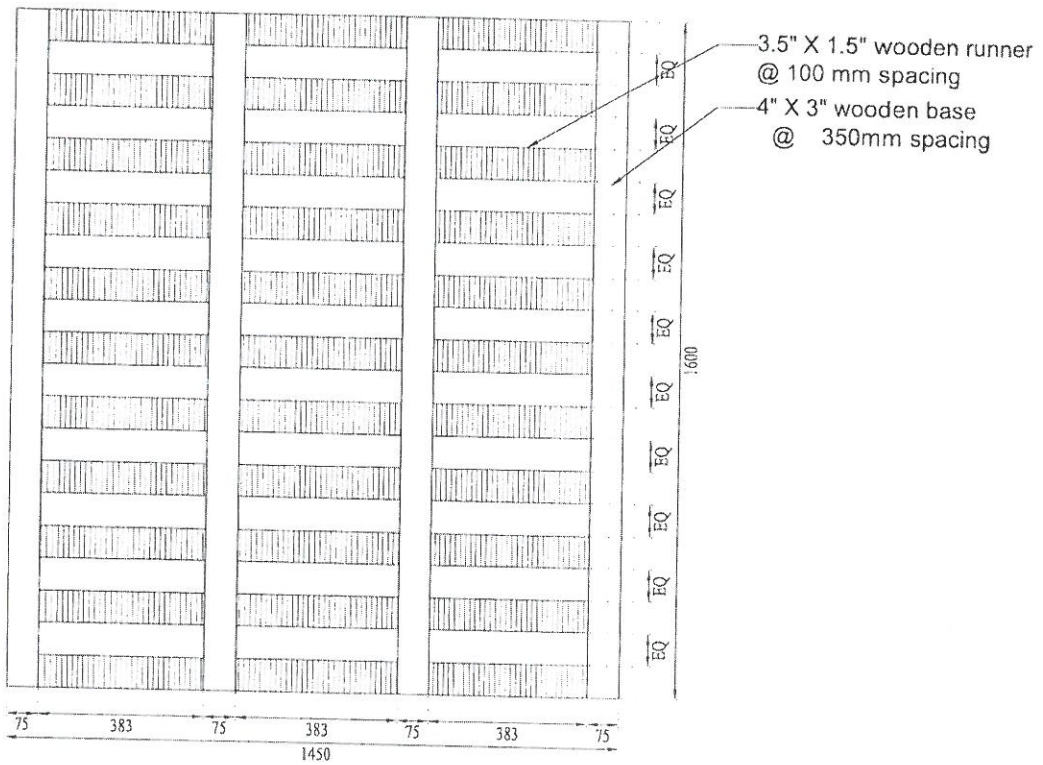

BOTTOM VIEW

Handwritten signature/initials in blue ink.